

SUPPLY CHAIN AND DEMAND DYNAMICS: CAN AI BE A DRIVING FORCE?

MASHAIL SALEH IBRAHIM ALSALAMAH

DEPARTMENT OF MANAGEMENT INFORMATION SYSTEM AND PRODUCTION MANAGEMENT, COLLEGE OF BUSINESS & ECONOMIC, QASSIM UNIVERSITY, SAUDI ARABIA,
EMAIL: mslamh@qu.edu.sa

Abstract

With today's global economy, the complexity of supply chains and the potential for their disruption are escalating, which highlights the need for companies to be agile and data-driven in making decisions. This research investigates how to apply Deep Learning (DL) methods to increase supply chain resilience, improve demand forecasting, and achieve operational efficiency. A quantitative approach was adopted to analyze over 1500 records of the supply chain data in Saudi Arabia, which include historical demand, inventory-level, shipment characteristics, and risk metrics. To preserve the most important information, we performed data pretreatment that included normalization, trend- and domain-informed imputation of missing values, and Principal Component Analysis (PCA) to reduce dimensions. The proposed Adaptive Electromagnetic Field Optimized Attention-enriched Memory Networks (AEFO-Att-MN) made use of the treated data for input. The networks used (LSTM) networks to take into account long term temporal dependencies along with attention mechanisms to highlight significant features and (AEFO) to optimize feature weights and model parameter. The framework was made with Python, TensorFlow, and PyTorch. The performance test showed that the model's ability to make accurate predictions has improved a lot. The Root Mean Squared Error (RMSE) is 0.412, the Mean Absolute Error (MAE) is 0.365, and the R² is 0.862. The results showed that there were fewer times when there was too much stock or not enough stock, better management of lead times, and shipments that were at risk are found before they happen. Moreover, the results showed that using advanced preprocessing and AEFO-Att-MN techniques together made forecasts much more accurate and made it easier to deal with unexpected events. This is useful information for AI-driven supply chain management.

Keywords: Supply Chain Resilience, Deep Learning (DL), Artificial Intelligence (AI), Demand Forecasting, Operational Efficiency, Inventory Optimization, COVID-19 Disruptions, Operations Management

1. INTRODUCTION

Global supply chains consist of suppliers, manufacturers, distributors, and retailers, collaborating to transfer products across the globe. The process includes obtaining raw materials, manufacturing, transportation, and finally delivering goods to consumers. The issue for all of these professionals is obtaining the appropriate information at the appropriate time, collaboration, and efficiency. The operation of these systems is essential for the cultivation of the modern connected marketplace and at the same time complicated and thus vulnerable. They require a significant amount of planning and continuous post-service management to continue functioning [1].

The varied and numerous events in the supply chain such as customer demand fluctuations, supplier delay events, transportation troubles, and even domestic and international economic or political unrest that can lead to stock-outs, overstocking, elevated costs and delivery delays. The complexity of supplier-to-market relations creates additional exposure to risk and continuation of typical management principles become ineffective to alleviate these problems in contemporary business practice. All these features bring about the need for adaptive, resilient, data driven practices to optimally maintain desirable performance [2].

The COVID-19 pandemic and other events have forced major disruptions in global supply chains; manufacturing was interrupted, transportation was slowed, and rapid adjustments in demand were necessary. These events pointed to the normal vulnerabilities of traditional systems, including a significant amount of rigidity, and not adequately considering risks, to name a few. Organizations suffered from irregularities in supply chains, which resulted in too little and too much inventory along with unnecessary delays in operations. This elicited the importance of how data driven, agile, intelligent supply chain solutions, should resolve unpredictable challenges [3].

Traditional supply chains fail to respond appropriately when there is an increase in demand or a disruption in the supply chain. Smart, agile, models based on AI and DL empower organizations to monitor supply chain activities in

real-time, build accurate forecasting, and take proactive decisions. This supply chain technology grants organizations the competitive edge to respond quickly to the market, ultimately leading to improved performance consistency and supply chain reliability. It also increases business resiliency [4], reduces costs, optimizes inventory, and improves operations.

Artificial intelligence enhances the field of operations management through automation, data management, and predictive analytical analysis. It enhances the risk exposure of organizations; optimizes inventory; and improves demand forecasting [5]. This results in effective operations, and reducing errors. AI set organizations in a position to react in a timely manner by engaging real-time tracking, while offering more contextually adaptive solutions to react to interruptions that may enhance competitiveness and operations in the midst of changing and more complex supply chains. Operations management seeks to ensure business activities are designed, organized, and optimized to maximize production and service delivery efficiency [6].

Nowadays, in businesses, this is achieved through technology, data analytics, and automation: maximizing resource utilization, minimizing costs, and increasing productivity. Effectiveness in operations management supports concrete strategic decisions for organizations to maintain competitiveness and market sensitivity to fluctuating demand and international pressure. Demand forecasting is a vital feature to sustaining supply chains because it enables organizations to forecast changes in the marketplace and customer needs. Being transparent and accurate about prediction aids organizations in planning for resource allocation, production scheduling, and inventory management. This enables organizations to exercised efficiency, provides product availability and managers to validate prescriptive stock levels, eliminating overages, shortages and operational overhead [7].

Organizations, nowadays, are also facing increased risk due to the threat of global disruption, volatility in the marketplace, technology failure, and geopolitical issues. Businesses carry the burden of making decisions, thinking ahead, and operating with future considerations, this responsibility is more important than ever. Considering interruptions due to pandemics, cyber threats, and scarcity of products and goods, and how businesses must operate and plan in consideration of these matters is best a practice in modern business planning. These uncertainties are pushing traditional systems of management to the breaking point, especially when considering the need for adaptable, technology driven plans that enable organizations to address constant change, build capacity, and endure in the case of uncertainty in global markets [8]. Applying information, analytics, and predictive models in real-time related to decision-making in the context of strategy, operationalizing information can become efficacious and invaluable in contingency planning. It assists managers in trending, demand forecasts, resources allocations, and risk and consequence management. Assuredly, companies that leverage large data, apply real-time precise, actionable, and accurate assessments, can confidently make slippery decisions, improve supply chain performance, increase throughput, reduce costs [9].

Aim of this research: The goal is to advance supply chain resilience and enhance operational efficiency using AI-powered DL models in monitoring real-time demand situations, inventory management, risk assessment and actions based on environmental and market conditions as represented by the AEFO-Att-MN model.

1.1. Contributions of research

- An AI-driven deep learning framework (AEFO-Att-MN) was developed to increase robustness in the supply chain and enhance demand forecasting.
- Adaptive Electromagnetic Field Optimization was coupled with an attention-based memory neural network to make the model more precise and adaptable.
- Demonstrated the framework's ability to mitigate stockouts, overstocking, and delays within the supply chain.
- Conducted quantitative analysis with real-world and publicly available datasets from Amazon case studies and Saudi transportation models.
- Completed comparative evaluation to traditional forecasting models to verify the integrity of improvements in MAE, RMSE, and R2 performance metrics.
- Enabled forward-looking at-risk shipments for proactive adaptive data-driven decision-making during disruptions.
- Provided value-added information to companies transitioning to a smart, AI-enabled supply chain system to keep their businesses viable and strategically prepared for the future.

Research organization: The research paper organization is as follows: **Section 1** covers the introduction and purpose of the study. The next **section 2** provides a summary of previous work. **Section 3** presents the proposed methodology working with a series of mathematical equations. **Section 4** presents performance evaluation and summary of the main findings, and **Section 5** concludes.

2. RELATED WORKS

Due to the pandemic, supply chain managers enhanced resilience through using the end-to-end visibility framework [10], which combined management, organizational, and technology elements. It served as a framework to inform potential disruptions and optimize operations but had limited generalizability.

The Partial Least Squares (PLS) regression framework [11] used structured questionnaires to examine the effects of agility, supply chain collaborations, and internal integration into resilience and long-term competitiveness in Indonesian manufacturing company settings, with limited generalizability due to self-reporting and lack of cross-industry validation. The validation was limited to computational scenarios [12]; risk averse mixed-integer nonlinear model prioritized recovery and identifying short-term disruptions, reducing risks from disruption, and maximizing facility placement, capacity, allocation flows, and resilient actions. It noted utility of preemptive investments and flexibility.

The Quality Function Deployment-Multi-Criteria Decision-Making (QFD-MCDM) framework was suggested [13] to relate resilience capabilities, benefits generation, and risks for sustainable supply chain disruptions, while the implementation identified priority risks and tasks, enhanced capacity, visibility, and provided disruption mitigations, although the generalizability was limited to a single case study. The Akaike Information Criterion (AIC) information system [14] was proposed to help display, collect, and analyze and contextualize incidents in the context of a combined model-driven and event-driven architecture. Implementation improved risk detection efficiency, reduced costs and increased speed, but it was limited to a single pharmaceutical supply chain.

The triple-P framework was developed by examining the complexity of Product, Partnership, and Process in terms of matching resilience options to supply chain types [15]. Implementation showed that strategies were influenced by the amount of integration and homogeneity of process. However, generalizability is limited, as it was solely based on executive interviews. The proposed framework integrating blockchain and artificial intelligence [16] improved supply chain resilience as well as operational performance and benefited economy, environment and society; however, it was not generalizable, because it only focused on the behavior of Chinese organizations, notwithstanding the differences amongst industries and regions.

The Interpretive Structural Modeling-Bayesian Network (ISM-BN) model [17] called on both the expert opinion and interdependencies to ascertain significant indicators of supply chain resilience. The results indicated that strategies were ranked effectively in three Indian manufacturing contexts; however, it is unlikely to apply to other sectors, regions, or more complicated situations. The smart resilient supply chain framework brought together demand forecasting, risk conditioned inference, and customer order clustering using planned-do-check-act decision making [18]. As a result of this process, they were able to produce better risk management and benchmark performance; however, they were not likely to be generalizable as their evidence-based ranges focused on single industries, regions, or new technologies.

The Double Exponential Smoothing (DES) proposed forecasting methods [19] were effective in predicting changes in demand and facilitating the management of inventory in food and beverage supply chains. The outcome was that the costs decreased, and the forecasts were accurate, but they couldn't be applied in all industries, parts of the world, or network configurations that were complex.

3. MATERIALS AND METHODS

Implementation increased accuracy in risk detection, cost efficiency, and speed; however, there was limited applicability to one pharmaceutical supply chain. The Triple-P framework was developed by assessing the complexity of Product, Partnership, and Process to match resilience options with supply-chain types [15]. Implementation pointed to strategies being affected by integration and process homogeneity, instead, the generalizability was limited as it was only based on executives through interviews.

The proposed framework integrating blockchain and artificial intelligence improved supply chain resilience and operational performance, which ultimately benefit the economy, environment, and society [16]. However, it did not have generalizability applied only to Chinese companies in isolation, while lacking consideration of differences in industries and regions. The Interpretive Structural Modeling-Bayesian Network (ISM-BN) model [17] used both feedback from experts and the interdependences in a three-case study to identify significant signs of resilience in supply chains. The studies appeared to prioritize strategies effectively in three instances from Indian manufacturing; however, it was not transferable to other industries, regions or more complicated situations.

The smart resilient supply chain framework [18] used Plan-Do-Check-Act decision-making to pull together demand forecasting, risk inference, working across customer order clustering for food waste reduction and recycling. This provided improved risk management capability, and more benchmark performance in using fishery topics; however, was not transferable to different industries, regions or new technological advancements.

Finally, Adaptive Electromagnetic Field Optimization (AEFO) is employed to fine-tune feature weights and model parameters, balancing exploration and exploitation to achieve optimal forecasting performance and robust decision support for supply chain resilience. Figure 1 shows the schematic work flow of the proposed system.

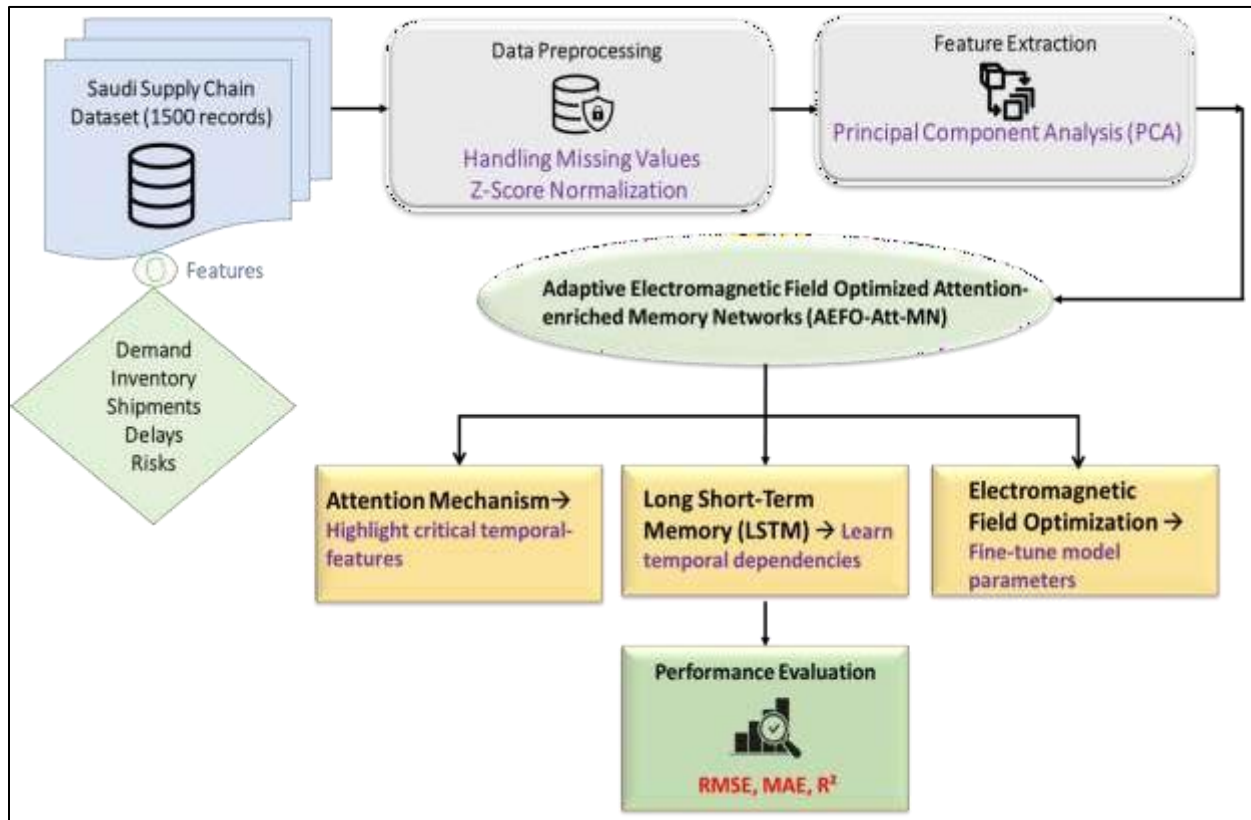

Figure 1. Structural Flow of the Proposed Model

3.1 Data Sources and Collection

The dataset has 1500 records of supply chain metrics from Saudi Arabia. The public Kaggle repository (<https://www.kaggle.com/datasets/programmer3/saudi-supply-chain-dataset/data>) is where these records brought from. It has information about demand and inventory, such as past demand, past forecasts, inventory levels, order quantities, lead time, and stockout flags. This information can be used to look at past demand patterns and make accurate demand forecasts. To determine the effectiveness of logistics and investigate delays, relevant shipment data is collected, including shipment ID, origin, destination, distance, transportation mode, transit time, hours delayed, fuel cost, and shipment status. Risk indicators (e.g., supplier risk, weather disruption, political risk, labor strikes, demand volatility, resilience score, and at-risk shipment) help to identify risks in the company and in the environment which allows for finding them before they happen. Data was divided into a training set (80%) and a test set (20%).

3.2 Handling Missing Values - Imputation and Cleansing of Key Supply Chain Metrics

Dealing with missing values is an important step in preprocessing the data set so the resulting supply chain forecasts and risk analysis can be done accurately. The approach that typically relies upon prior trends and business relationships is value imputation for missing values on important variables such as historical demand, forecast demand, inventory positions, order quantity, lead time, delay hours, shipment status and such. This is a way to respect the relational and temporal aspects of the data set, the modeling can accurately learn demand changes in relation to delay in shipments and risk operational implications such as a chain reaction of delays. Subsequent to this phase, the cleaned and full features, past demand, predicted demand, inventory level, order quantity, lead time, delay hours, shipment status, supplier risk score, and resilience score-are sent to the feature extraction phase for additional transformation and dimensionality reduction, which facilitates solid and precise deep learning predictions.

3.2.1 Data Preprocessing Using Z-Score Normalization

Operational and logistical data for supply chain forecasting are normalized using Z-score normalization, which standardizes feature values by centering and scaling them to ensure consistency across variables. This process enhances the reliability and performance of the DL. The process makes the data have a standard deviation of one and centers it around zero. Equation (1) shows a feature w using the Z-score.

$$1) w' = \frac{w - \text{mean}(w)}{\text{std}(w)}$$

where w' is the normalized value utilized for modeling, $\text{mean}(w)$ is the mean value of the original supply chain feature w , and $\text{std}(w)$ is its standard deviation.

3.3 Principal Component Analysis (PCA) using Feature extraction

The dimensionality of the Saudi supply chain dataset is high, and to retain the most informative features, PCA is applied. Fake parts are made from original features that capture the most variation in the dataset. This helps the AI model focus on the most important data for figuring out risks, optimizing inventory, and predicting demand. To make a dataset that doesn't have a mean, we take the mean of each feature and subtract it from the dataset. The covariance ($Cov_{w_1w_2}$) between two features is computed as Equation (2).

$$2) Cov_{w_1w_2} = \frac{\sum(W_1 - M_1)(W_2 - M_2)}{m}$$

where W_1 and W_2 are instances of the features, M_1 and M_2 are the respective means, and m is the total number of records. For datasets with multiple features, the covariance matrix (D) is represented as follows in Equation (3).

$$3) D = \begin{pmatrix} u(W_1) & d(W_1, W_2) & \dots & d(W_1, W_o) \\ d(W_1, W_2) & u(W_1) & \dots & d(W_2, W_o) \\ \dots & \dots & \dots & \dots \\ d(W_1, W_o) & d(W_2, W_o) & \dots & u(W_o) \end{pmatrix}$$

The covariance matrix D captures variances $u(W_i)$ of each feature W_i and covariances $d(W_i, W_j)$ between feature pairs, where o is the total number of features. The variance recorded is quantified by the eigenvectors (eig) of the directions of maximal variance and the related eigenvalues. Ordering eigenvectors by descending eigenvalues allows selection of the most informative components. The top eigenvectors form the reduced feature vector in Equation (4), retaining essential dataset information while reducing dimensionality.

$$4) FeatureVector = (eig^1, eig^2, eig^3, \dots, eig^m)$$

Finally, a newly reduced feature space is generated from the dataset using Equation (5).

$$5) NewDataset = [FeatureVector]^s [Data]^s$$

This PCA-based feature selection lets the model use the most important supply chain features while keeping the most variation and lowering the number of dimensions. This means that the AI system can accurately predict demand, find shipments that are in danger, and make the supply chain stronger.

3.4 Adaptive Electromagnetic Field Optimized Attention-enriched Memory Networks (AEFO-Att-MN) model is designed to improve demand forecasting, inventory optimization, and supply chain resilience

The proposed AEFO-Att-MN framework integrates attention mechanisms to prioritize critical features, LSTM networks to capture complex temporal dependencies, and AEFO optimization to fine-tune feature weights and parameters. This synergy improves the accuracy, stability, and adaptability of forecasts for long-term management of urban environmental facilities. Using focused feature learning, temporal memory modeling, and intelligent optimization, the model makes sure that decisions are strong and work well.

3.4.1 Enhances memory representation to capture dependencies for accurate forecasting using Attention-enriched Memory Networks (Att-MN)

The attention mechanism, which is based on how the brain sees things, focuses on the most important parts of supply chain forecasting. It gives more weight to important features and less weight to less important ones. Scaled dot-product attention is utilized, derived from supply chain time-series data as delineated in Equation (6).

$$6) P = \text{softmax} \left(\frac{QK^T}{\sqrt{L}} \right) \cdot V$$

where P represents the output of the attention mechanism, Q is obtained from the TCN (Temporal Convolutional Network) output, K and V are derived from the original input sequence, and L is the input feature length. The keys and values are computed as Equation (7 and 8).

$$7) K = J \cdot X_i + a_i$$

$$8) V = J \cdot X_u$$

In this case, J is the original time-series data from the supply chain, X_i and X_u are trainable weight matrices for figuring out keys and values, and a_i is the bias vector that is added to the keys. This mechanism lets the model give more weight to important parts of the supply chain, which improves the accuracy of demand predictions, the ability to spot shipments that are at risk early on, and the overall resilience of the supply chain.

Att-MN is a machine learning technique used to model long-term temporal dependencies in urban environmental sensor data. Its four components the input gate, forget gate, output gate, and update mechanism manage information transmission, forgetting, and storing to generate accurate future predictions for sustainable facility operation as follows in Equation (9).

$$9) j_s = \sigma(X_j * [g_{s-1}, w_s] + a_i)$$

where j_s represents the input gate activation controlling new information flow into the cell, The input gate's weight matrix is represented by X_j , while the previous time step's hidden state is represented by g_{s-1} , w_s is the current input (e.g., sensor readings, energy load, or environmental metrics), and a_i is the bias term. The sigmoid function σ regulates the flow of information between 0 and 1. It is shown in Equation (10).

$$10) e_s = \sigma(X_e * [g_{s-1}, w_s] + a_e)$$

where e_s denotes the forget gate activation that filters past memory contributions. The forget gate's weight matrix is called X_e , and its bias is called a_e . This step is crucial to remove outdated patterns in environmental data, such as

transient peaks or outliers. In order to enable the model to preserve any long-term dependencies, the method used to update the cell state determines which candidate values should be added to the memory cell. This is outlined mathematically as Equations (11 and 12).

$$11) M d_s = \tanh(X_d * [g_{s-1}, w_s] + a_d)$$

$$12) d_s = e_s * d_{s-1} + j_s * d_s$$

Where X_d is the weight matrix for the cell update, X_d is the bias term, d_s is the previous cell state. The multiplication with e_s allows forgetting irrelevant past signals, while j_s decides how much of the new candidate state is retained. In the context of this research, this enables the model to balance historical sensor trends with real-time data streams. The gate for output controls the generation of the ultimate concealed condition, which represents the model's interpretation of relevant temporal patterns. It is expressed as shown in Equations (13 and 14).

$$13) p_s = \sigma(X_p * [g_{s-1}, w_s] + a_p)$$

$$14) g_s = p_s * \tanh(d_s)$$

where X_p is the output gate's weight matrix, a_p is its bias, g_s is the updated hidden state at time s , and p_s is the output gate activation. The LSTM architecture enhances the prediction of environmental dynamics by acquiring temporal dependencies from multimodal sensor streams, forecasting urban facility operations, and facilitating adaptive resource management, thereby improving sustainable facility planning. Figure 2 shows what an LSTM cell looks like on the inside. It shows how the network can use the cell's ability to selectively store, update, and output information from sequential time-series data to find long-term dependencies and short-term trends for accurate forecasting.

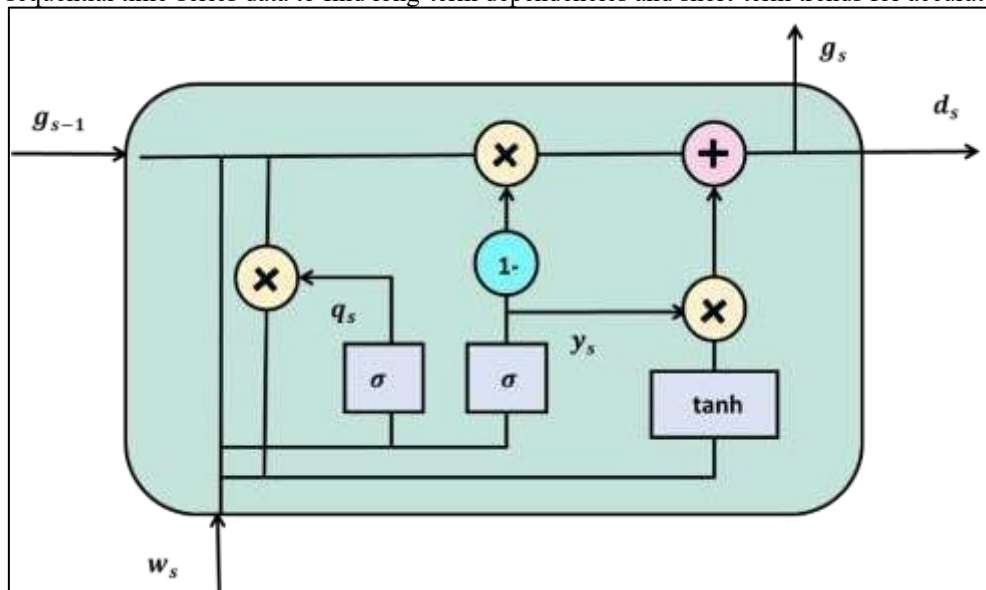

Figure 2. LSTM Cell Internal Mechanism

3.4.2 Adaptive Electromagnetic Field Optimization (EFO) Steering Intelligent Feature Weighting and Model Fine-Tuning

To optimize the model parameters and feature selection weights that influence urban environment facility monitoring and adaptive decision-making EFO algorithm is employed. Traditional optimization techniques often lead to local convergence, especially in high-dimensional environmental data involving sensor dynamics, public facility usage, and environmental conditions. EFO is used to find a balance between exploration and exploitation, which makes sure that the algorithm moves toward a global optimal solution. Equation (15) shows how to make the first population.

$$15) EMPE_i^j = Lower_i + \text{random}(\text{Upper}_i - \text{Lower}_i), j = 1, \dots, \text{Number of EMPE}; i =$$

1, \dots, \text{Number of electromagnetic of Electromagnetic Particle (EMPE)}

Here, $EMPE_i^j$ represents the j^{th} electromagnetic of the i^{th} electromagnetic particle (candidate solution). Lower and

$Upper_j$ are the lower and upper bounds of each variable (e.g., feature weight or parameter), and random is a uniform random number in $[0,1]$. The algorithm categorizes solutions based on their fitness performance into three fields. This adds more variety to each iteration, which helps the algorithm get out of local minima. The roulette wheel method (RWM) uses Equation (16) to find the best solutions by figuring out how fit each new particle.

$$16) EMPE_i^{new} = \begin{cases} EMPE_i^{RWNi} \text{ if random} \\ < \text{Probability of selecting variables} \\ & \text{in generated particle} \\ EMPE_i^{neutral_i} + (\varphi + \text{random}) \\ (EMPE_i^{positive_i} - EMPE_i^{neutral_i}) \\ | - \text{random}(EMPE_i^{negative_i} - EMPE_i^{neutral_i}) \text{ or else} \\ \{ i = 1, \dots, \text{Number of electromagnets} \} \end{cases}$$

Roulette Wheel Method (RWM) enhances the exploitation capability by probabilistically selecting better solutions more frequently. Finally, the selection probability is updated adaptively to smoothly transition from exploration to exploitation as iterations progress, is shown in Equation (17).

$$17) (PSV)_{rate} = PSV_{rate}^{min} + \frac{\text{rate} - \text{rate}^{min}}{\text{Maximum iteration} - \text{iteration}} \times (PSV_{rate}^{max} - PSV_{rate}^{min})$$

In this case, PSV_{rate}^{min} and PSV_{rate}^{max} are the lowest and highest values for the selection probability, and iteration and maximum iteration are the current and total number of iterations. EFO uses this structured optimization to figure out the best variable weights and parameter settings for the model that senses the environment. This leads to better detection accuracy, more flexibility, and better decision support for the long-term management of urban public facilities. Algorithm 1 shows how the system should work.

Pseudocode 1: AEFO-ATT-MN

```

BEGIN AEFO-Att-MN
Initialization
num_slots = 10; slot_dim = 64
input_dim = 128; feat_dim = 64; out_dim = 5
Initialize memory M[10 × 64], θ_f, θ_a, θ_o randomly
α = 0.1 # EM field strength
β = 0.01 # step size
ε = 0.001 # convergence
epochs = 50; batch_size = 32
Attention Mechanism
FUNCTION Attention(q, M):
scores = softmax(q · M^T) # [1×10]
RETURN scores · M # [1×64]
Forward Pass
FUNCTION Forward(x):
f = Feature(x, θ_f) # [1×64]
q = Transform(f, θ_a) # [1×64]
c = Attention(q, M) # [1×64]
RETURN Output([f || c], θ_o) # [1×5]
AEFO Parameter Update
FUNCTION AEFO_Update(param, grad):
EM_force = α * grad / (||param|| + 1e - 8)
RETURN param - β * EM_force
Training
FOR epoch = 1..epochs:
FOR each batch:
y = Forward(x)
loss = CE(y, target)
grads = Backprop(loss)
Update θ_f, θ_a, θ_o, M using AEFO_Update
α = α * 0.99 # decay EM force
IF loss < ε: BREAK
Prediction
FUNCTION Predict(x):
RETURN Forward(x)
END AEFO-Att-MN
    
```

4. RESULT

The AEFO-Att-MN proposed framework improves forecasting demand, optimizing inventory, identifying emerging risks, and overall resilience of the supply chain, achieving better performance than traditional methods. As seen through graphical and quantitative methods compared to programmed baseline models, operational efficiency, bottlenecks and predictive ability appear to be positively tweaked or influenced. To train the system, Keras 2.2.4 was utilized, meanwhile, testing happened using Tensorflow ("Python," 3.6). The outcomes show the AEFO-Att-MN proposed framework performs much stronger than conventional methods at analyzing resilience and predicting supply chain events. Graphs reveal delays in transportation, fuel costs, resilience scores, supplier risks, and bottlenecks. Important measure of operation metrics matter that confirm just how these two metrics together can help to show how both transport delays and changes in fuel costs can adversely affect the overall performance and efficiency of the supply chain can be revealed in Figure 3.

Figure 3(a) reveals delays in hours for each mode of transport. It indicates that sea, road, and air all have a similar median delay overall. The variation illustrates that operations are not always predictable, warranting the use of AI for making the best predictions possible for an improved supply chain. From Figure 3(b), fuel costs fluctuate according to the status of the shipment; usually, a late shipment costs less than on-time shipments. There seem to be a pattern; timely shipments tend to cost more or even less fuel than late shipments. This demonstrates the balance between cost and efficiency in the supply chain operation.

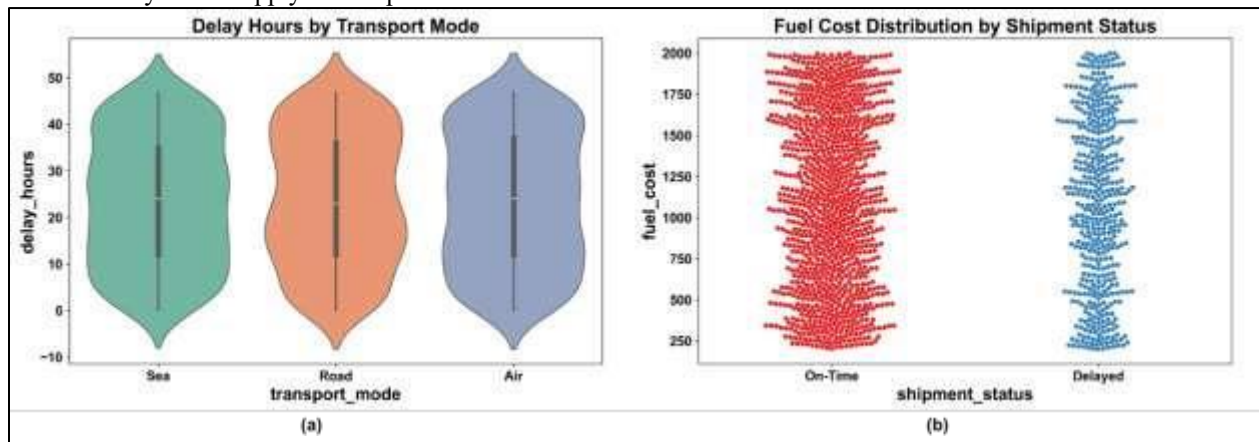

Figure 3: Graphical representation of Delay hours and fuel cost analysis across transport modes

Figure 4 illustrates the resilience of the supply chain and its transportation effectiveness while also documenting what different factors apply to operational reliability and efficiency. Figure 4(a) illustrates the density distribution of the resilience scores across the supply chain participants. The densities skew more to the 0.5 - 0.9 resilience scores suggesting good operational performance illustrated by operational stability and adaptability. Higher density scores with more scores in the middle balanced would imply all supply chain nodes are likely strong. Figure 4(b) then follows the correlation of distance and delay hours showing that longer distances naturally create a bit of a delay to arrival, but the density distribution illustrates how other outside factors would have negative influence on delivery. Overall, this illustrates how important predictive planning is to support a resilient and efficient supply chain.

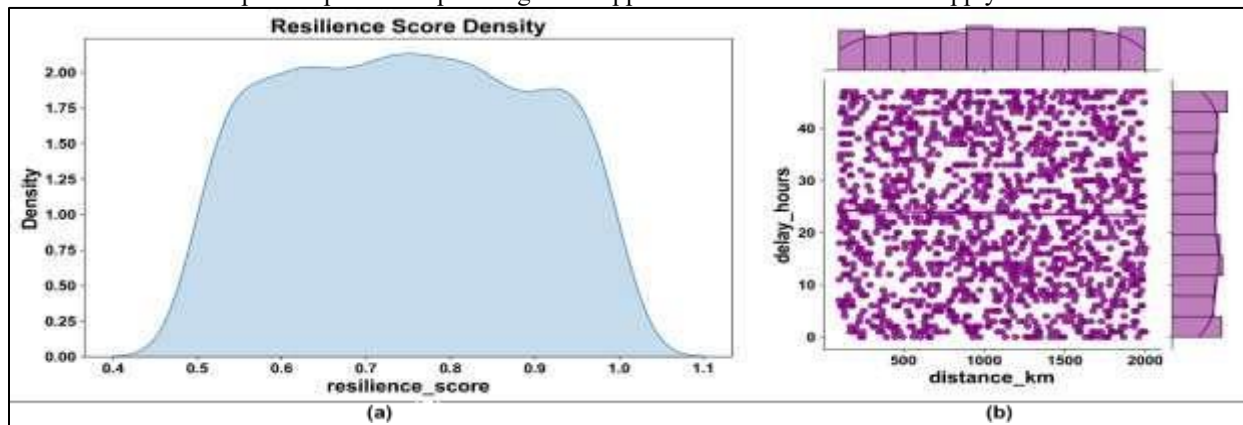

Figure 4: Graphical representation of Supply chain resilience scores and distance versus delay analysis

Supplier risks and transit performance by transport modes is graphic in Figure 5. It also suggests what factors influence reliability in the supply chain. In Figure 5(a), raw supplier risk scores for Sea, Road and Air are presented. The median

risk for both Air and Road is slightly upward, indicating that these two forms of expedited or land-based logistics may also offer less reliability. Sea Transportation scored moderate risk and inspection was consistent. In Figure 5(b), distance vs. transit time is captured using a hexbin plot. More distance typically equals more time for delivery. This trend shows that distance greatly influences logistics performance and is significant for predictive optimization in supply chain management.

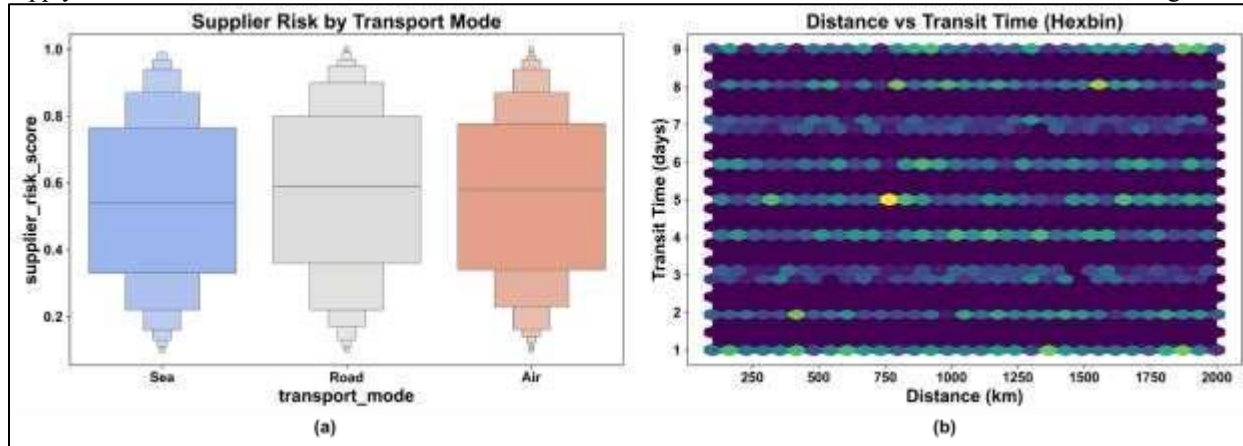

Figure 5: Graphical representation of Supplier risk scores and distance versus transit time analysis

Figure 6 illustrates the performance of the supply chain by illustrating shifting relationships and process bottlenecks. Figure 6(a) illustrates a parallel coordinate plot that illustrates how historical demand, inventory level, lead time, and resilience score are interconnected with one another. Two different groups of lines are displayed by the red and blue lines, and this makes it easier to distinguish patterns and relationships among these variables. Figure 6(b) illustrates a supply chain funnel that indicates how orders reduced from 238,966 to merely 1,350 shipped and 1,275 delivered products. This indicates where the supply process slows.

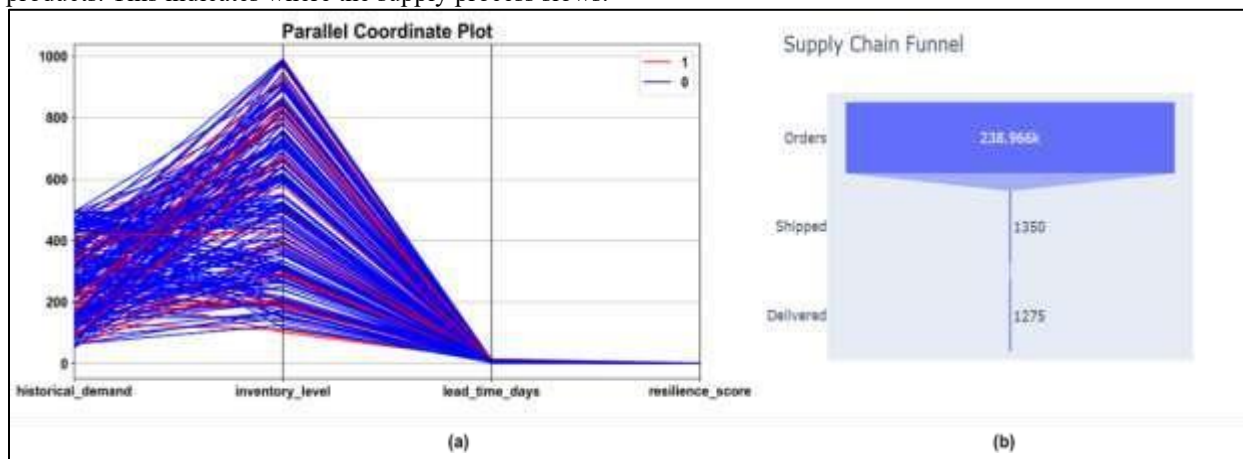

Figure 6: Graphical representation of Supply chain variable relationships and order funnel bottleneck analysis

Table 1 displays a comparison of the performance results of the proposed model, AEFO-Att-MN, against currently accepted models such as MLP Regressor [20], Elastic Net [20], XGBoost [20], Random Forest [20], and Linear Regression [20]. This section demonstrates that the AEFO-Att-MN has improved accuracy by validating well-established methods and reference measures/rules of thumb through established performance measures of R^2 , RMSE, and MAE.

In figure 7(a), RMSE was used to provide forecast accuracy portending the level of agreement between actual observations and forecasted supply chain demand values. The AEFO-Att-MN provided the best RMSE value of 0.412, exceeding Random Forest (1.014) and Linear Regression (0.985) in predictive accuracy by minimizing prediction error and delivering higher reliability.

The MAE is another measure of average prediction error to determine forecasting accuracy. Figure 7(b) shows the AEFO-Att-MN had the best MAE of 0.365, as compared to traditional models with a measurement of 0.866 to 1.059. Therefore, the AEFO-Att-MN had excellent accuracy with little space between predicted demand and actual demand. The model's ability to explain variation in demand forecasts is measured by R-squared (R^2), which is an indicator of predictive accuracy and model trustworthiness. Figure 7(c) indicates that the proposed AEFO-Att-MN has an R^2 of 0.862, which is much higher than the other models (i.e., Linear regression = 0.003) demonstrating higher forecasting opportunity and a great ability to explain variances in demand forecasting.

Table 1: Proposed Model Outperforms Baseline Regression Methods

Model	RMSE	MAE	R-squared (R^2)
Linear Regression [20]	0.985	0.866	0.003
Random Forest [20]	1.014	0.878	-0.055
XGBoost [20]	1.091	0.918	-0.223
Elastic Net [20]	0.988	0.873	-0.001
MLP Regressor [20]	1.259	1.059	-0.628
AEFO-Att-MN (Proposed)	0.412	0.365	0.862

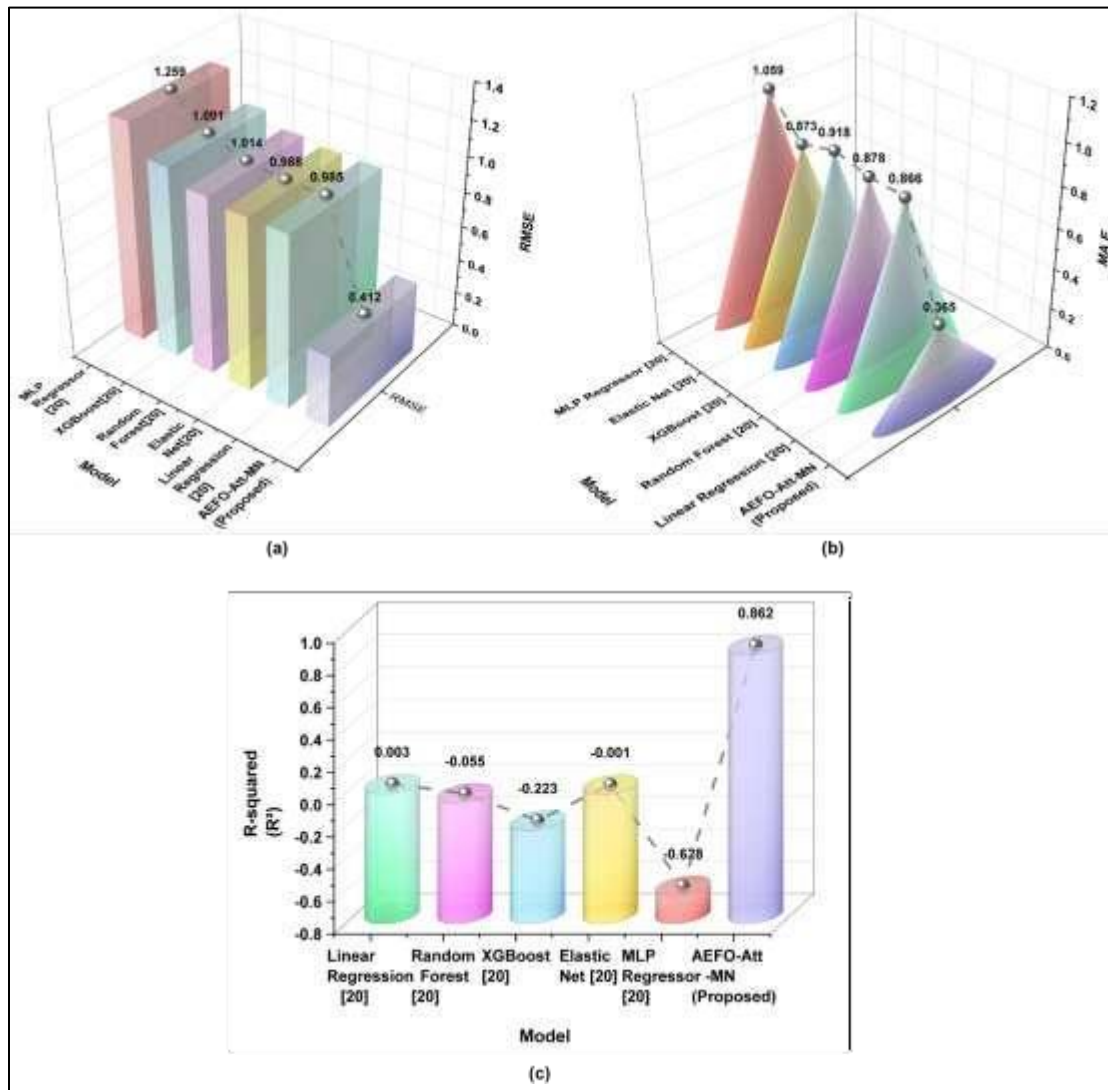

Figure 7: AEFO-Att-MN outperforms traditional models in RMSE, MAE, and R^2

5. DISCUSSIONS

The discussion presents evidence that different frameworks are not particularly good at generalizing. The discussion also introduced various ways AEFO-Att-MN could help with operational efficiency in general, as well as the flexibility of supply chains. The limitations of the suggested frameworks and models were presented to reveal that these frameworks could not generalize or assess validity. The end-to-end visibility indicated limited generalizability [10], while the PLS regression framework encountered issues with self-reporting and lack of validation across industries [11]. The validation of the risk-averse mixed-integer nonlinear model was limited to computational scenarios [12]; the QFD-MCDM framework was valid within a single case [13].

Similarly, the AIC information system was only usable within the one pharmaceutical supply chain [14]; to further, the Triple-P framework was more difficult to generalize because it was only validated through executive interviews [15]. The blockchain-AI framework is not as applicable to other industries or regions since it is only useful for Chinese

companies, and generalizability does not account for differences [16], England [17]. The ISM-Bayesian Network model was limited in wider applications due to sectors, regions, and levels of complexity in its framework [17]. Current models have high error rates and can only slowly adapt to nonlinear, changing patterns. The AEFO-Att-MN model is a modification to mitigate these errors through using attention-based memory and adaptive optimization for improving accuracy, stability, and robustness [20]. The AEFO-Att-MN deep learning framework increases resilience across supply chains by permitting better demand forecasts, less surplus and shortage, effectively managing inventory, optimizing lead time, hypothesizing risk, and facilitating intelligent and flexible operations.

6. CONCLUSION

The AEFO-Att-MN A model was significantly developed to improve operational efficiency and resiliency in the supply chain by exploring various frameworks and advanced techniques such as AI-based analytics and deep learning approaches. Examples of classical frameworks are end-to-end visibility, PLS regression, risk-averse mixed-integer nonlinear models, and AIC information systems as well as new deep learning framework efforts such as QFD-MCDM and the Triple-P framework developed herein to enable strategic planning for adversity, operational efficiencies, and resilience for supply chains. However, their applicability was frequently constrained to very specific and narrowly defined situations, often limited by self-reported data, focused on only one industry or case study, or limited to validation based on computational or interview-based research methods. This identifies an overarching need for a more general and cross-industry assessment of frameworks and structures. The AEFO-Att-MN deep-learning framework, however, demonstrated to effective improvements by forecasting demand effectively and efficiently, lowering excess and out-of-stock inventory situations, reduced effective lead-time, and predicting shipments at risk before it is occurring, enabling supply chain agility and intelligence. However, even with demonstrated improvements, there remains over the traditional frameworks with respect to adopting better outcomes across a broader geographical region, industries, and operationally varying levels of technological sophistication (robustness). Future research may focus on integrating cross-sector validation, real-time data analytics, and hybrid AI models to enhance supply chain resilience and promote intelligent, sustainable operations globally.

REFERENCES

1. Ivanov, D., Tsipoulanidis, A., & Schönberger, J. (2021). Basics of supply chain and operations management. In *Global supply chain and operations management: A decision-oriented introduction to the creation of value* (pp. 3–19). Cham: Springer International Publishing. https://doi.org/10.1007/978-3-030-72331-6_1
2. Sodhi, M. S., & Tang, C. S. (2021). Supply chain management for extreme conditions: Research opportunities. *Journal of Supply Chain Management*, 57(1), 7–16. <https://doi.org/10.1111/jscm.12255>
3. Rozhkov, M., Ivanov, D., Blackhurst, J., & Nair, A. (2022). Adapting supply chain operations in anticipation of and during the COVID-19 pandemic. *Omega*, 110, 102635. <https://doi.org/10.1016/j.omega.2022.102635>
4. Hendriksen, C. (2023). Artificial intelligence for supply chain management: Disruptive innovation or innovative disruption? *Journal of Supply Chain Management*, 59(3), 65–76. <https://doi.org/10.1111/jscm.12304>
5. Gunasekaran, A., & Ngai, E. W. (2012). The future of operations management: An outlook and analysis. *International Journal of Production Economics*, 135(2), 687–701. <https://doi.org/10.1016/j.ijpe.2011.11.002>
6. Aldahmani, E., Alzubi, A., & Iyiola, K. (2024). Demand forecasting in supply chain using uni-regression deep approximate forecasting model. *Applied Sciences*, 14(18), 8110. <https://doi.org/10.3390/app14188110>
7. Kazancoglu, I., Ozbiltekin-Pala, M., Mangla, S. K., Kumar, A., & Kazancoglu, Y. (2023). Using emerging technologies to improve the sustainability and resilience of supply chains in a fuzzy environment in the context of COVID-19. *Annals of Operations Research*, 322(1), 217–240. <https://doi.org/10.1007/s10479-022-04775-4>
8. Gutierrez-Franco, E., Mejia-Argueta, C., & Rabelo, L. (2021). Data-driven methodology to support long-lasting logistics and decision making for urban last-mile operations. *Sustainability*, 13(11), 6230. <https://doi.org/10.3390/su13116230>
9. Ivanov, D. (2021). Digital supply chain management and technology to enhance resilience by building and using end-to-end visibility during the COVID-19 pandemic. *IEEE Transactions on Engineering Management*, 71, 10485–10495. <https://doi.org/10.1109/TEM.2021.3095193>
10. Tarigan, Z. J. H., Siagian, H., & Jie, F. (2021). Impact of internal integration, supply chain partnership, supply chain agility, and supply chain resilience on sustainable advantage. *Sustainability*, 13(10), 5460. <https://doi.org/10.3390/su13105460>
11. Riccardo, A., Daria, B., & Dmitry, I. (2021). Increasing supply chain resilience through efficient redundancy allocation: A risk-averse mathematical model. *IFAC-PapersOnLine*, 54(1), 1011–1016. <https://doi.org/10.1016/j.ifacol.2021.08.120>
12. Hsu, C. H., Yu, R. Y., Chang, A. Y., Chung, W. H., & Liu, W. L. (2021). Resilience-enhancing solution to mitigate risk for sustainable supply chain—An empirical study of elevator manufacturing. *Processes*, 9(4), 596.

<https://doi.org/10.3390/pr9040596>

13. Fertier, A., Martin, G., Barthe-Delanoë, A. M., Lesbegueries, J., Montarnal, A., Truptil, S., Benaben, F., & Salatge, N. (2021). Managing events to improve situation awareness and resilience in a supply chain. *Computers in Industry*, 132, 103488. <https://doi.org/10.1016/j.compind.2021.103488>
14. Cohen, M., Cui, S., Doetsch, S., Ernst, R., Huchzermeier, A., Kouvelis, P., Lee, H., Matsuo, H., & Tsay, A. A. (2022). Bespoke supply-chain resilience: The gap between theory and practice. *Journal of Operations Management*, 68(5), 515–531. <https://doi.org/10.1002/joom.1184>
15. Yang, Z., Guo, X., Sun, J., Zhang, Y., & Wang, Y. (2022). What does not kill you makes you stronger: Supply chain resilience and corporate sustainability through emerging IT capability. *IEEE Transactions on Engineering Management*, 71, 10507–10521. <https://doi.org/10.1109/TEM.2022.3209613>
16. Badhotiya, G. K., Soni, G., Jain, V., Joshi, R., & Mittal, S. (2022). Assessing supply chain resilience to the outbreak of COVID-19 in Indian manufacturing firms. *Operations Management Research*, 15(3), 1161–1180. <https://doi.org/10.1007/s12063-021-00236-6>
17. Fu, W., Jing, S., Liu, Q., & Zhang, H. (2023). Resilient supply chain framework for semiconductor distribution and an empirical study of demand risk inference. *Sustainability*, 15(9), 7382. <https://doi.org/10.3390/su15097382>
18. Ghafour, K. M., & Aljanabi, A. R. A. (2023). The role of forecasting in preventing supply chain disruptions during the COVID-19 pandemic: A distributor-retailer perspective. *Operations Management Research*, 16(2), 780–793. <https://doi.org/10.1007/s12063-022-00327-y>